

### Electric Power Engineering Research Laboratory

#### Brief Overview

The Electric Power Engineering Research Laboratory is engaged in the advancement of fundamental technologies, including electrical insulation, lightning protection, fault current control and high power testing technologies for power transmission and distribution equipment. It is also developing next generation power equipment and new electric power technologies.

#### Achievements by Research Theme

##### High-voltage & Insulation

###### 【Objectives】

To make diagnostic technology for electric power equipment sophisticated, we address clarification of deterioration mechanism for various insulation and sealing materials, making external insulating technology of transmission line advanced and improvement of accuracy of high-voltage measurement.

###### 【Principal Results】

- We clarified partial discharge properties (relation between quantity of discharge and phase angle) of delamination defects on a simulated insulating layer of electric cable junction. These properties are useful for on-site diagnostics using small size resonance type power supply.
- The overall uncertainty of peak voltage measurement for several hundred kV lightning impulse voltage was evaluated to be 0.3 % for the measuring system with a voltage divider, constructing as the Japanese national standard. This means the accuracy of the measuring system is the same as European national standards [H09001].

##### Lightning and Electromagnetic Environment

###### 【Objectives】

Developing the logical technologies for lightning protection measures and insulation coordination in the electric power systems of ICT society is an object in this field. In addition, this field aims at establishing the EMC technology in the power supply facilities and consumer facilities.

###### 【Principal Results】

- The phenomena of lightning strikes on wind mills has become clear through observations of lightning strokes and measurement of the peak value and electric charge of lightning currents. Furthermore, the statistical characteristics of the lightning phenomena have also become clear [H09005].
- A new calculation method using the numerical electromagnetic field analysis was developed for analyzing induced lightning voltages on distribution lines. The method has clearly explained the influence of the ground resistance, ground wires and lightning arresters on the induced lightning voltage [H09002].
- In light of the new guidelines issued by ICNIRP, a calculation method of the electric fields and current that were induced inside a human body exposed to the magnetic field was developed. In addition, the issues to be solved for applying the calculation method were also examined [H09013].

##### Applied High Energy Physics

###### 【Objectives】

We will develop simulation techniques of pressure rise in electric equipment caused by fault-arc to complement high power short-circuit tests. In addition, we will also develop innovative measurement technologies using laser or high energy particles and work on its application to diagnosis of power delivery apparatus.

## [Principal Results]

- We developed a simulation method to predict internal pressure-rise caused by short-circuit fault-arcs, which lead to damage of electric power apparatus [H09021]. We also developed a numerical model for evaluation of pressure rise and propagation characteristics caused by arc discharge in the protective pipe of CVT cable [H09018].
- High-energy electrons ranging from 16 to 17 MeV, which is sufficient level to produce positrons, were successfully generated by irradiation of ultra-short laser pulses on a gas jet target [H09012].

## Electric Power Application

### [Objectives]

To promote electrification of transportation sector, etc., we will develop application technologies of power electronics related to dc power distribution and electric energy applications, an electromagnetic transient analysis program for power system and super conductive electrical power equipment.

### [Principal Results]

- A transient analysis program for power systems shown in Fig. 1 has been put in practical use. A new steady-state initialization algorithm taking harmonics and imbalance conditions into account has been developed [H09007].
- A prototype of bidirectional and wireless charging system for future electric vehicles was developed. Dual directional charge and discharge were demonstrated successfully [H09015].
- A prototype of the 2-axis Electromagnetic Stirring System with AC Superconducting Magnets was developed. It can be applied for stirring high viscous molten metal. Strong and stable stirring was demonstrated [H09016].

## High Current Technology

### [Objectives]

To estimate performance of electric equipment at a short-circuit fault, we improve short-circuit test techniques and establish measuring techniques for power frequency currents.

### [Principal Results]

- In cooperation with STL (Short-Circuit Testing Liaison) comparison tests of high current shunts in high power laboratories in Asia with an STL reference shunt were carried out and the test results showed the shunts tested had a good performance for high current measurements.

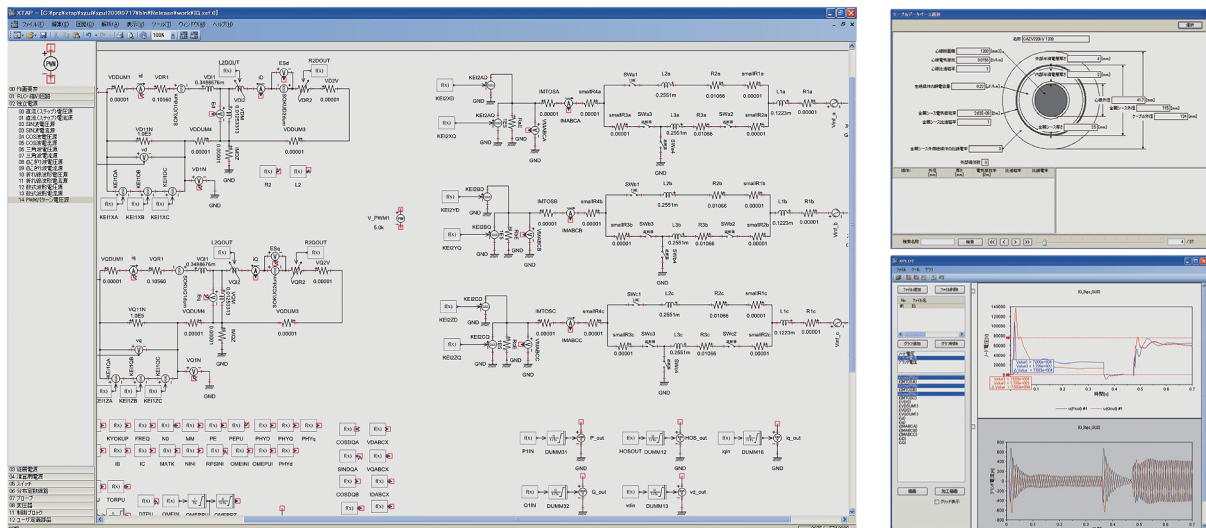

**Fig. 1 Screenshots of the transient analysis program**

Schematic editor (left), line constants calculation routine (upper right) and viewer of waveforms (lower right)